

This Horse in a Few Hours can Produce Enough Electric Energy to Light a House

### MAKING HORSE ILLUMINATE HOUSE WITH ELECTRICITY

An Ohio inventor has devised an apparatus intended to transform a horse's energy into electricity with which to light a house, or charge storage batteries for the motor car which has replaced it for family driving purposes. The arrangement consists of a circular sweep which operates a dynamo, the animal causing power to be generated as it walks slowly around the 14-ft. track. An electric bell and whip attachment keeps the horse going stead-

ily ahead. If the animal should slow down too much, or should stop, the bell would immediately commence ringing and the whip striking, neither of them stopping until the horse regained a normal gait. It is claimed that in approximately three hours a horse in this manner can develop enough electric energy to illuminate a small house for more than an evening, or store sufficient current to operate various appliances. The device is intended for use on farms where electric power is not provided.

## **Dabbling with the Physics of Electricity—*It's Child's Play!***

One of the most remarkable things, which I have to keep re-learning about physics, is that most phenomena seem comprehensible when they behave according to our absurdly simplistic human notions of how they should behave. But when studying further, the phenomena become wildly convoluted and self-contradictory— since we started out with badly flawed ideas about the basic physics. So everything we know is wrong— because we think like humans—not electrons, not fields, not atoms....

But you would think that the “theory” of electricity has been well worked out by now. But here’s a test:

- 1) What carries the energy in a simple electrical circuit?
  - a-Electrons,
  - b-Holes,
  - c-God knows!
  
- 2) What returns on the ground or return wire?
  - a-Electrons,
  - b-Holes,
  - c-God knows!
  
- 3) In a coaxial cable, exactly where is the energy carried?
  - a-In the center conductor,
  - b- In the shield,
  - c-God knows!

Okay, here’s an easy one:

- 4) How big is an electron?
  - a- $r_e = 2.8179402894 \times 10^{-13}$  cm
  - b-I’m waiting for a call from Stockholm.
  - c-God knows!

If you answered “c” to all four questions, you are correct, but we can shed considerable light on the subject—

Here’s what Richard Feynman says about Electrical Theory: (By the way Feynman shared the Nobel Prize for Quantum Electrodynamics [QED] which is the complete quantum mechanical description of electromagnetism.

In the Feynman lectures we read:

“We ask what happens in a piece of resistance wire when it is carrying a current. Since the wire has resistance, there is an electric field along it, driving the current. Because

there is a potential drop along the wire, there is also an electric field just outside the wire, parallel to the surface. There is, in addition, a magnetic field which goes around the wire because of the current. The E and B are at right angles; therefore there is a Poynting vector directed radially inward, as shown in the figure. There is a flow of energy into the wire all around. It is of course, equal to the energy being lost in the wire in the form of heat. So our "crazy" theory says that the electrons are getting their energy to generate heat because of the energy flowing into the wire from the field outside. Intuition would seem to tell us that the electrons get their energy from being pushed along the wire, so the energy should be flowing down ~or up! along the wire. But the theory says that the electrons are really being pushed by an electric field, which has come from some charges very far away, and that the electrons get their energy for generating heat from these fields. The energy somehow flows from the distant charges into a wide area of space and then inward to the wire."

Let's start with some simple but startling truths:

1) You can't expect electrons to carry energy to the load because a coulomb (a miniscule amount of electrons), a meter from another coulomb electrostatically repel each other with about a Megaton of force. (So there's probably some kind of taxpayer-funded DARPA electronic weapon based on this fact in our future...).

2) Electrons don't carry signals or information either because they are far too slow. It takes days for an electron to go a mile. Electromagnetic fields and disturbances in them, do the whole job.

3) The notion of ground current as used-up tired electrons slowly returning home to battery rehabilitation is wrong. BOTH the high potential and ground return conductors do identical things, but with opposite polarities—even in DC circuits.

4) Electrons don't carry energy to the load because they usually don't get there anyway. Most circuits just don't connect power and load in any contiguous way.

5) Coaxial cables are high frequency waveguides because the energy transmitted in them is almost entirely within the insulation. An amazing demonstration of this is that the limiting wave velocity is exactly equal to the speed of the electromagnetic wave in the particular material out of which the insulation is made. The importance of this is directly proportional to frequency. For audio purposes it matters little.

"Skin Effect" is a 1957 film-tribute to Brigitte Bardot, and also what happens to electrons that increasingly drift towards the surface of a conductor at high frequencies. Why do we care about this when electrons don't do much anyway? This is interesting only because the center of conductors at high frequencies have no function. This is easily seen in HF induction coils made of hollow tubing instead of solid.

The "pigtailed" where the coax shield is twisted into a lead and both the inner conductor and twisted up shield lead are treated as separate wires is deadly to high frequency signals above a Megahertz. The shield should be terminated by any method that does not decrease the impedance of the shield or the inner

conductor. There are many ways to do this, but they all use some collar arrangement to terminate the messy coax shield. Any coax catalog has lots of solutions.

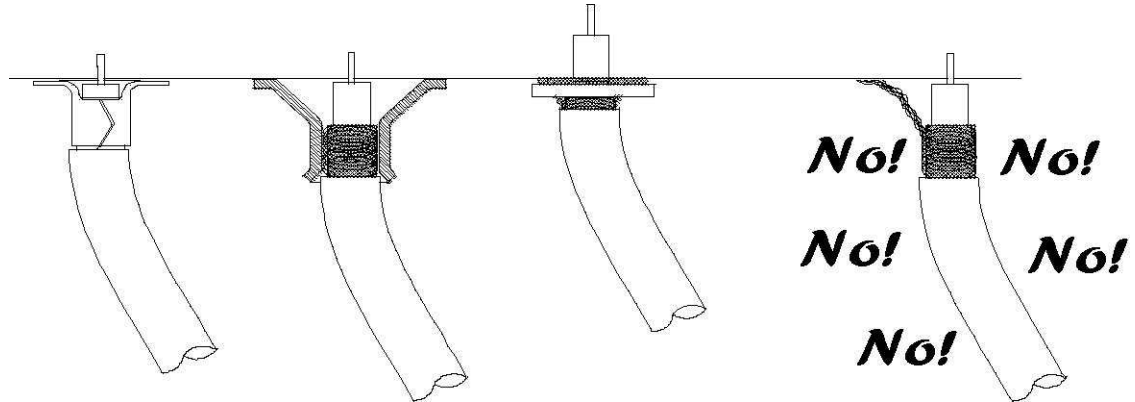

But yikes...! So it turns out that the simplest DC circuit operation is wildly difficult to explain, but basically the electromagnetic fields carry the energy, not the electrons. They are just there to move and cause the magnetic field. The electrons have only an electric field, and it is only the electrons movement through space that generates a magnetic field. If you followed alongside an electron, you wouldn't see ANY magnetic field. This is the difference between static electricity and the regular stuff. Static electricity has no magnetic field because the electrons aren't moving **RELATIVE TO THE OBSERVER.**

How big is an electron? There is a "classical size" which is useful in some theoretical work (and wrong), but it just seems not have a size. So answer "c-" is again correct.

<http://science.uniserve.edu.au/school/curric/stage6/phys/stw2002/sefton.pdf>  
and if this (excellent!) paper doesn't blow your mind, try--

[http://sites.huji.ac.il/science/stc/staff\\_h/Igal/Research%20Articles/Pointing-AJP.pdf](http://sites.huji.ac.il/science/stc/staff_h/Igal/Research%20Articles/Pointing-AJP.pdf) (I borrowed the Feynman quote here)

[http://www.st-andrews.ac.uk/~www\\_pa/Scots\\_Guide/audio/part6/page3.html](http://www.st-andrews.ac.uk/~www_pa/Scots_Guide/audio/part6/page3.html)

Electromagnetics Explained: Part of the EDN Series for Design Engineers by Ron Schmitt